

Core Balance Earth Leakage Sensors

Blakley Electrics Residual Current Sensors were originally designed for incorporation within our range of Residual Current Protection and Distribution Assemblies, which have found wide usage in industry and education. The many features and benefits of Blakley Sensors has resulted in their extensive incorporation by panel builders within controlgear and switchgear assemblies, as well as by OEMs making special assemblies for applications ranging from UV Print Drying to medical machinery.

The range is based on three models: the **ELS series**, which has a fixed sensitivity; the **VELS series**, which is similar to the ELS but has adjustable sensitivity and time delay; the **VRCD series**, which also has adjustable sensitivity and time delay but has a separate current transformer and is therefore suitable for higher current applications.

The basic product range encompasses the following:

- Suitable for load currents up to approximately 1000 amps.
- Standard auxiliary voltages of 110, 230 and 400 volts, 50 Hz. Sensors suitable for other voltages and frequencies are available to order, including for dc and high frequency supplies.
- Sensitivities from 5 mA to 2 amps (subject to model) to provide protection for people and plant.
- Adjustable time delay sensors to ensure discrimination in multi-layer RCD installations.
- A volt free c/o contact that can operate a shunt-trip, under volt release, contactor coil or indicator system (audible or visual).
- A 'Supply On' LED.
- A remote test facility.
- A high level of immunity to the presence of DC current, which has led to the widespread use of sensor based RCDs within the "Third Rail" areas of the UK rail network. The devices respond to all faults from AC to full wave rectified DC.
- When used in combination with a suitable circuit disconnecter Sensors provide protection in accordance with BS4293.
- Sensors are not damaged by insulation tests at test voltages of up to 1000 volts DC.
- The response time of our sensors is inversely proportional to the leakage level, which helps reduce spurious tripping due to transient spikes.
- ELS series sensors are set to trip at 90% of their Rated Tripping Current, which helps to minimise nuisance tripping due to over sensitivity (BS 4293 permits a trip range that is between 50% and 100% of the Rated Tripping Current).



VELS with Optional Test Button Plate



ELS series



VRCD and 65mm ID CT

THE POWER PROFESSIONALS

HIGHER POWER TRANS POWER SAFE POWER TEM POWER PRO POWER GREEN POWER

THE COMPANY RESERVES THE RIGHT TO CHANGE PRODUCTS WITHOUT PRIOR NOTICE.



Cert. No. 902091

SPDS6 - 12/07

ELS Series

The ELS series sensor is a fixed sensitivity device available in a range of sensitivities from 5mA to 500mA and is suitable for load currents of up to approximately 125A (the load cables have to pass through the aperture of the sensor, which has an internal diameter of 32 mm). ELS sensors are housed within a white ABS enclosure, measuring 148H x 57W x 25D mm. The enclosure incorporates a test button and a remote test facility is also provided. Auxiliary connections are via externally mounted, grab type terminals.

To order an ELS series sensor please specify the auxiliary voltage (110, 230 or 400V, 50Hz) and the sensitivity (5, 10, 20, 30, 100, 200, 300 or 500 mA).

VELS Series

Similar to the ELS series device, the VELS series has adjustable sensitivity (from 100mA to 1A) and adjustable time delay (from 0 to 1 second). Adjustment is via control knobs fitted to the front of the sensor. The VELS sensor is not fitted with a test button but is supplied with a loose test button for connection to the 'remote test' terminal of the device.

To order a VELS series sensor specify the auxiliary voltage (110, 230 or 400V, 50Hz).

VRCD series

The VRCD series sensor comprises of a separate control unit connected to a round current transformer (CT) via a multicore cable. The sensitivity adjustment range is from 100mA to 2A and the time delay adjustment range is from 0 to 3.5 seconds. The VRCD is not fitted with a test button but is supplied with a loose test button for connection to the 'remote test' terminal of the control unit. The test circuit extends from the control unit to a separate test winding on the CT. Therefore, if the control unit and CT should become disconnected, the test button will fail to operate the associated disconnecter, indicating a fault. The circuit load cables have to pass through the CT and CT's are available with internal diameters of 45, 65, 100, 150 and 200 mm, making the VRCD series suitable for load currents ranging from 100A to 1000A, dependent upon the number and type of conductor.

To order a VRCD series sensor specify the auxiliary voltage (110, 230 or 400V, 50 or 60 Hz) and the internal diameter of the associated CT (45, 65, 100, 150 or 200mm).

Typical wiring diagrams for sensors working in conjunction with MCBs or MCCBs incorporating shunt trips or under volt releases.

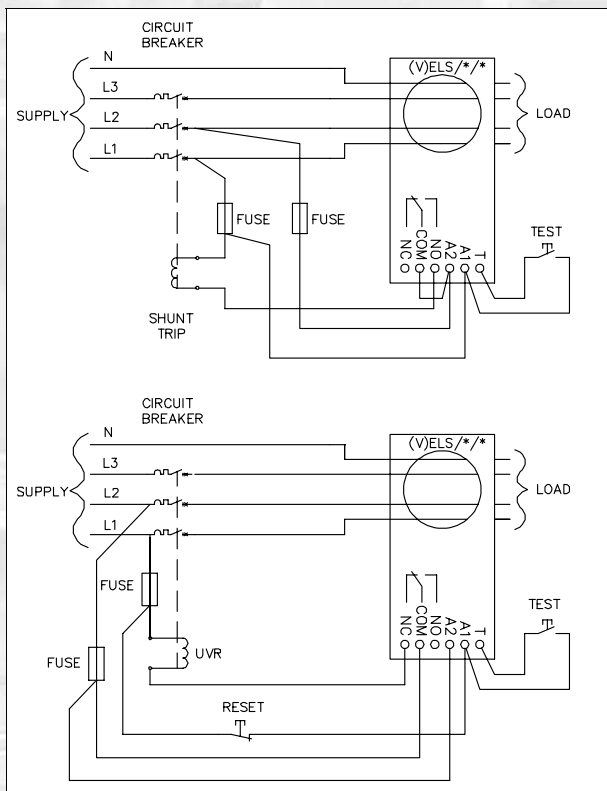

ELS and VELS series

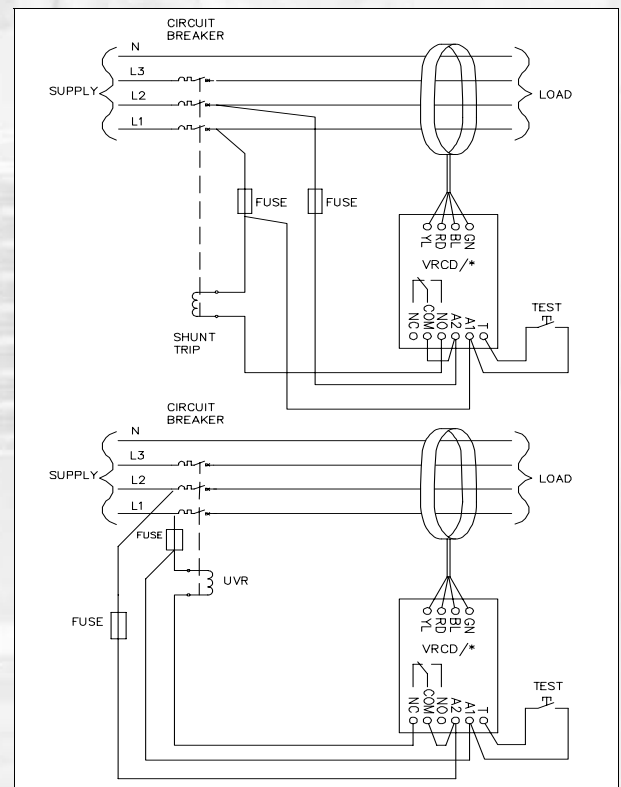

VRCD series

- **SOUTH** 1 Thomas Road, Optima Park, Crayford, Kent DA1 4GA Tel: 0845 074 0084 Fax: 0845 074 0085
 - **NORTH** Unit 55, Monckton Road Ind Estate, Wakefield WF2 7AL Tel: 0845 074 0086 Fax: 0845 074 0087
- www.blakley.co.uk • sales@blakley.co.uk

BLAKLEY
ELECTRICS