

## ***Tunnel Power and Lighting Assemblies***

The operating conditions encountered in tunnels are amongst the harshest found in the Construction and Civil Engineering industries. Over the course of a major project, equipment is often subject to extreme treatment. This can be the result of obvious problems associated with the presence of brackish water and very high levels of dust, or it can be the less predictable abuse that occurs during processes such as shotcreting or when miners carve out crossovers from hard rock deep underground using roadheaders and other items of heavy plant. In order to cope with the extreme conditions, BS6164 provides valuable guidance on voltages, equipment enclosures, cabling, electrical protection and lighting systems. In addition, through our involvement with many tunnel projects, we have acquired much practical experience in the detailed design of Mains Distribution Assemblies, Tunnel Distribution Assemblies, Cable Link Boxes, Tunnel Power Transformers (3300V, 1000V and 400V) and 110V Lighting systems. Therefore, although many projects require custom built assemblies, we are usually able to draw on our experience and provide project specific assemblies that are both fit for purpose and ideally suited to the application. The equipment described on this data sheet does not address the requirements associated with HV supplies for Tunnel Boring Machines, which are generally subject to specific inquiry.

### **General**

A wide variety of LV electrical distribution equipment can be required on a tunnel project. Main LV supplies into tunnels are often provided with a back-up stand-by generator and our Mains Distribution Assemblies (MDAs) can incorporate Manual or Automatic Changeover systems to switch between Mains and Stand-by power. MDAs can also incorporate bus couplers (manual or automatic) to enable generator backed-up supplies to be restricted to essential loads such as ventilation fans, pumps and lighting (see separate data sheets on MDAs and AMF panels).

Within tunnels, 400V supplies are required to feed heavy plant, conveyors, compressors, pumps, fans, etc. Due to the nature of the operations, a lot of equipment needs to be plug-in or extendable, so that it can move forward with the work face. Tunnel Distribution Assemblies are generally fitted with industrial socket outlets to BS EN 60309, which ensure quick, safe and reliable connections. Standard socket outlets are available in ratings of 16A, 32A, 63A and 125A and are generally individually protected by circuit breakers with 30 mA RCD protection. At 63A and 125A connectors incorporate pilot pins, which enables Earth Continuity Monitoring protection to be provided. This ensures that portable / transportable equipment is always effectively earthed and also provides an electrical interlock to prevent insertion or withdrawal of plugs on load. Higher current sockets, up to 630A rating, are available to feed specialist plant. Hard wired MCBs and MCCBs can also be incorporated and these are protected by medium sensitivity RCDs with adjustable time and current settings. 110V is required for tunnel lighting, task lighting and power tools and these supplies are derived from step-down transformers.

From an equipment design perspective, as far as possible, distribution equipment is wall mounted and generally housed in robust, IP55 enclosures. Wherever practical, sockets and switchgear are fitted to the sides of enclosures to reduce the risk of mechanical damage in confined locations. Distribution assemblies and transformers are installed at regular intervals along the tunnel and supplies will often be fed from a single cable, with the main feed cable entering and exiting assemblies through opposite sides of enclosures. The loop-out feed can be controlled by an isolator, which is independent of the local distribution supplied from the assembly. The loop-out feed can also be located in a separate section of the enclosure to enable connection to be made whilst the rest of the assembly is "live", allowing the electrical system to be extended as tunnelling advances.

**THE POWER PROFESSIONALS**

**HIGHER POWER   TRANS POWER   SAFE POWER   TEM POWER   PRO POWER   GREEN POWER**

THE COMPANY RESERVES THE RIGHT TO CHANGE PRODUCTS WITHOUT PRIOR NOTICE.



Cert. No. 902091

TMPDS15 - 05/10

## Tunnel Distribution Assemblies and Transformers

Distribution Assemblies and Transformers are installed to provide 400V and 110V for power and lighting. On long tunnels, to overcome volts drop, cabling is often over sized and termination distances within enclosures are increased accordingly. Alternatively, tunnel lighting and power supplies can be fed at 1000V or 3300V and tunnel transformers can have a secondary and a tertiary winding to provide 400V to supply larger plant and machinery and a tertiary winding to provide a 110V Reduced Low Voltage (RLV) supply for lights and smaller tools. Due to limitations in the practical length of 110V circuits, the spacing of Distribution Assemblies and Transformers is effectively dictated by the light level required in a tunnel. Typically a 5' 110V fitting, spaced every 10 metres, installed at a height of 3M in a 4M diameter tunnel, will provide an average illumination level of 15 to 20 lux. A design of this type would require a transformer every 400 metres with the transformer located at the mid-point. Higher light levels will require luminaires at a closer spacing (typically every 5 or 7 metres) which has the dual benefit of reducing the contrast (the different levels of illumination between fittings) as well as increasing the overall light level. However, due to excessive volts drop, a closer spacing of luminaires will usually require transformers to be positioned at closer intervals (every 200 to 250 metres with the transformer at the mid point of each section). Shown below are some typical tunnel distribution schemes.

### Typical Tunnel Distribution - 400V

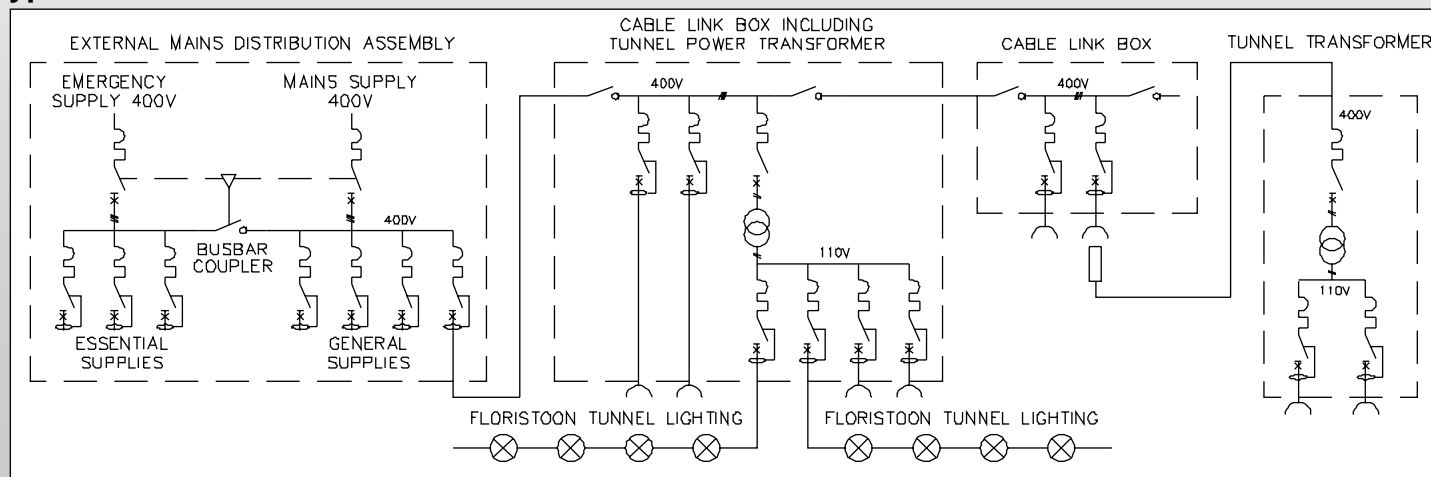

#### 400V Distribution

When tunnel distribution is carried out at 400V, Cable Link Boxes can be provided which will typically accept incoming and outgoing SWA cables with a cross section of 95mm<sup>2</sup> 4C and switchgear rated up to 250A. The main switch can control the outgoing feeder cable only, with terminations located in a segregated section, enabling the system to be extended as tunnelling advances without the need to isolate the overall link box. Distribution equipment would normally comprise of 400V sockets rated from 16A to 125A, individually protected by MCBs and RCDs. Sockets rated at 32A and above should be interlocked to prevent withdrawal or insertion on load, in accordance with the requirements of BS6164. Monitored Earth (ME) protection can be provided for 63A and 125A sockets, which incorporate an additional pilot pin. ME protection can be used to ensure mobile plant is always effectively earthed. It also provides an electrical interlock for all connectors in the circuit. Transformers can be built into the Link Boxes or they can be installed separately.

#### 110V Distribution

Tunnel transformers provide a 110 volt Reduced Low Voltage supply to feed hand held power tools and temporary tunnel lighting. Typical power ratings are 5kVA and 10kVA, continuously rated. To reduce volts drop on the supply, transformers usually have a 400V "2 wire" primary winding. In addition, tapings of -5% and -10% can be incorporated to help ensure that the output voltage is maintained at 110V, even at the end of long cable runs. To be in strict accordance with BS6164, transformers should be single-phase and have a 110V centre-tapped to earth secondary i.e. a maximum line to earth voltage of 55V. On the secondary side a combination of 16A and 32A 110V sockets are fitted. These are protected by MCBs and 30 mA RCDs, again in accordance with BS6164.



Combined assembly comprising a 200A 400V Loop-out isolator and local 400V and 110V distribution

## Typical Tunnel Distribution Scheme - 1000V

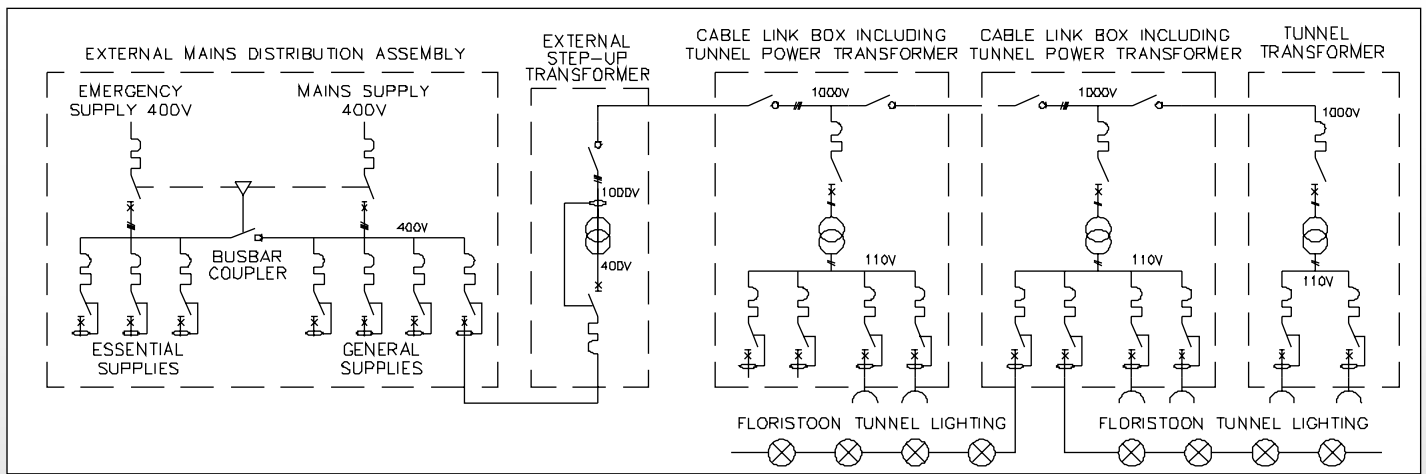

### 1000V Distribution

On long runs it is often beneficial to step-up the voltage to 1000V at the entrance to the tunnel and to step-down to 400V and 110V at regular intervals to meet local power and lighting requirements. In addition to reducing volts drop by 60%, the use of 1000V has a number of other advantages: (i) it is defined as Low Voltage within BS7671; (ii) standard XLPE / SWA cables can be used; (iii) switchgear and fusegear is reasonably sized and priced (in comparison to MV gear). A typical arrangement would be to install a 50 kVA step-up, 400:1000V transformer at the entrance to a tunnel and install 10 no. 5 kVA 1000:110V Tunnel Transformers at 300 metre centres along the tunnel (the transformers to be located at the mid-point of each 300M section). Additional 110V sockets can be incorporated for small tool use and task lighting.

## Typical Tunnel Distribution Scheme - 3300V

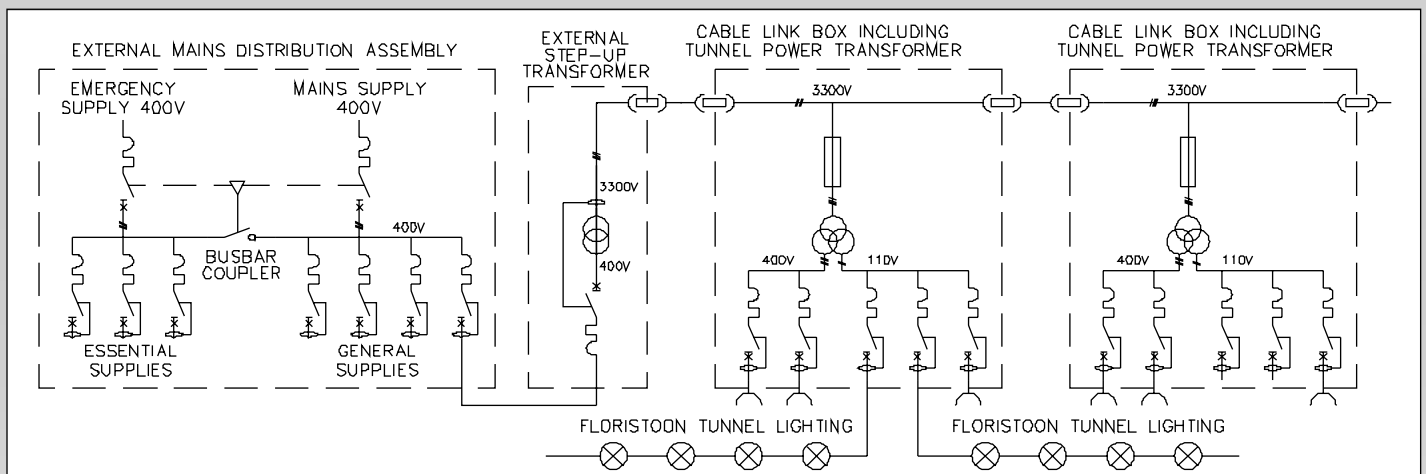

### 3300V:400V / 110V and 3300V:110V Tunnel Transformers

On the longest runs it may be necessary to step-up the voltage to 3300V at the entrance to the tunnel and step down to 400V/230V and 110V at regular intervals. Stepping up to 3300V does require the use of special cable and connectors but the distances that can be fed from a single source are significant (many kilometres). The usual practice is to fit 3300V "Half Couplers" to the transformers, which can be electrically interlocked. This "plug and socket" system enables the installation to be quickly extended as the tunnelling progresses.

Due to the size of 3300V switchgear, all protection for the circuit is provided at the source but the supplies to each transformer are individually fuse protected. 3300V transformers can incorporate a single-phase 110V output to feed tunnel lighting and small power. Alternatively dual output transformers can be incorporated to provide 400V power for larger machines as well 110V for tunnel lighting and small power. In this configuration the 110V output is three-phase, resulting in a line to earth voltage of 63.5V, which is still within the Reduced Low Voltage limits specified in BS7671 but is greater than the 55V to earth preferred in BS 6164. However, all outlets are protected by 30mA RCDs, which provide supplementary Basic protection. Therefore the increased level of shock risk with this arrangement is minimal.



Combined assembly incorporating a 3300:400/110V 35 kVA transformer with 400V and 110V distribution (all covers removed)

## Tunnel Lighting

Fluorescent lighting at 110V is most commonly installed to light long stretches of tunnels. Fluorescent lighting is energy efficient and competitively priced. It is also available with self-contained, integral, 3 hour emergency battery packs. Standard luminaires are 5' singles or 2' twins, although other versions are available. Luminaires with high frequency controlgear are now available and these will work down to much lower voltages, although there is a gradual loss of light output as the voltage drops beneath 100V.

Our PowerLine and Flori-2X systems of plug-in fluorescent lighting have all been widely used to supply tunnel lighting and we believe that there is also an application for our new Flori-67/4P system in tunnels that do not operate 24/7. These products can all be made from LSF cable and are fully described on separate Higher Power Data Sheets but a brief outline is included below.

Discharge floodlights are often used in large diameter tunnels, particularly in locations where a higher level of lighting is required, such as at cross-overs and at work faces. The introduction of 110V metal halide floodlights at 150W and 400W has made it an easier task to provide high powered floodlights from local transformers without compromising safety through the use of mains voltage (230V) floodlights.

### PowerLine

PowerLine is available in 3C cable with a 2.5mm<sup>2</sup> and 4mm<sup>2</sup> cross section and it has been widely used to supply lighting in tunnels as the 4mm<sup>2</sup> version allows longer runs of 110V luminaires to be supplied. PowerLine has a moulded "Tee Drop" every 5 metres or every 10 metres which is fitted with a standard 16A 110V connector. Pre-wired luminaires are supplied complete with hooks, tube and a 2 metre tail fitted with a 16A plug. A possible disadvantage of utilising PowerLine is that the use of a standard 16A 110V coupler means that there is a risk that lights can be unplugged and power tools can be plugged-in in place of luminaires. However, this is not usually an issue on wide diameter tunnels where the luminaires and PowerLine are installed at a height of 4 to 6 metres. Full details of PowerLine can be found on Higher Power data sheet ref. HPDS4.

### Flori-2X

Flori-2X has been very widely used in tunnels, as it utilises a unique 3 pin connector system which does not interchange with standard 16A 110V connectors. Flori-2X is available in 100 metre lengths of 1.5mm<sup>2</sup> and 2.5mm<sup>2</sup> 3C cable with outlets every 5 metres, every 7 metres and every 10 metres. Pre-wired luminaires are supplied complete with hooks, tube and a 2 metre tail with moulded-on Flori-2X adaptor. Full details of Flori-2X can be found on Higher Power data sheet ref. HPDS10.

### Flori-67/4P

Flori-67/4P utilises 4 core cable and has been developed to allow emergency fittings to be switched off without draining the batteries or damaging the tubes through repetitive discharging. Flori-67/4P operates in conjunction with transformers incorporating automatic time clock or manual switch control of lighting circuits. The system allows Emergency and Non-Emergency luminaires to be fed from the same supply but enables all or some of the lights to be switched off at the end of a shift without damaging batteries or tubes within Emergency luminaires. Full details of Flori-67/4P can be found on Higher Power data sheet ref. HPDS31.

### Other Products

Refer to Higher Power data sheets ref. HPDS12, HPDS25, and HPDS28 for information on festoon lighting strings, 110V discharge floodlights and bulkhead lights.



PowerLine



Flori-2X



Flori-67/4P

- **SOUTH** 1 Thomas Road, Optima Park, Crayford, Kent DA1 4GA Tel: 0845 074 0084 Fax: 0845 074 0085
  - **NORTH** Unit 55, Monckton Road Ind Estate, Wakefield WF2 7AL Tel: 0845 074 0086 Fax: 0845 074 0087
- [www.blakley.co.uk](http://www.blakley.co.uk) • [sales@blakley.co.uk](mailto:sales@blakley.co.uk)

**BLAKLEY**  
E L E C T R I C S