

SPECIFICATION & INSTALLATION DATA

Blakley Electrics specialise in the design and manufacture of double-wound transformers in ratings from 100VA to 25kVA, single and three phase. In addition to a wide range of standard models, we have considerable experience in the design and manufacture of windings and enclosures of non-standard configuration, including auto-wound transformers. Detailed below is information on the design and construction of our transformer windings and enclosures, which generally apply to our whole range. In addition, information is provided on connections, circuit protection and other installation considerations. Please contact our Customer Service Centres for more detailed Technical or Installation information on our transformers or their application.

SPECIFICATION

WINDINGS

Blakley transformer windings are generally manufactured in accordance with BS EN 61558 Parts 1, 4 and 6. Transformers are continuously rated, except for the PPT, PT1 and TT series of portable powertool transformers, where ratings are intermittent. Transformer ratings are based on an ambient temperature of 30°C. Tropically rated and inhibited transformers can be supplied to order.

Isolation

Isolation between the primary and secondary windings is in accordance with BS EN 61558. Various methods are employed to achieve the necessary degree of isolation. Most commonly isolation is through the incorporation of an earthed screen between the primary and secondary windings. However, on high volume products, isolation is achieved through the use of split section bobbins with the primary wound in one section and the secondary in the second. In specialist installations where the supply is not earthed or the integrity of the earth is in doubt, isolation can be achieved through the use of reinforced insulation between windings.

Insulating Materials

Blakley continuously rated transformers are designed to operate at temperatures in accordance with BS2757 Insulation Class E. However, to ensure long life and reliable operation, transformer coils are wound using polyester enamel coated copper conductors to BS6811: Section 3.2, which have a temperature rating of 180°C, far in excess of the designed maximum winding temperature of 120°C. Coils are varnish impregnated and stove dried.

ENCLOSURES AND FINISH

Steel enclosures are designed and fabricated in-house. They are available in wall, portable or combined wall/floor mounting configurations. Generally enclosures are ventilated and provide protection to IP21 or IP 23. Non-vented enclosures to IP44, IP55 and IP65 can be supplied dependent on the ambient temperature, application etc.

As standard, steel enclosures are fabricated from 16swg (1.5mm) mild steel sheet and finished in a durable, electro-statically applied polyester powder paint with a phosphate pre-treatment.

If enclosures are to be installed in a heavily polluted environment, they can be flame sprayed in zinc to BS2569 followed by a top coat of electro-statically applied polyester powder paint. Alternatively, enclosures can be hot dip galvanised to BS 729, which may require the fabrication of special enclosures to withstand the rigours of galvanizing.

Insulated enclosures can be wall mounting or portable and are generally moulded from glass reinforced plastic (GRP). Portable insulated enclosures are compound filled and incorporate a stout carrying handle.

TRANSFORMER PROTECTION

Ideally, overcurrent protection should be provided for both the primary and secondary windings. Protection for the primary winding can either be provided at the source or incorporated into the transformer itself and should be thermally rated in accordance with the continuous rating of the transformer. Short circuit protection should be "motor-rated" (Type "D" MCBs to BS EN 60898 or motor-rated fuses). Each output of a multi-secondary winding transformer should be separately protected against overload.

INSTALLATION

EARTHING

When ordering a double wound transformer it is essential to specify the required connection of the output winding with respect to earth. PLEASE SEE OVER THE PAGE FOR INFORMATION ON DIFFERENT EARTHING OPTIONS.

CIRCUIT PROTECTION

A variety of protective devices can be incorporated into enclosed transformers, including fuses, MCB/MCCBs and RCDs. It should be remembered that the overcurrent protection that is incorporated to protect the transformer windings against overload may not provide distribution circuits with automatic disconnection protection against earth faults or even basic overcurrent protection (particularly when the rating of the transformer exceeds the capacity of individual output circuits). It is important that the characteristics of the secondary overcurrent protection devices takes into account the PSC level at the transformer output terminals (the impedance voltage is typically 4%) and the earth fault loop impedance of the individual secondary circuit(s). In many instances multiple secondary protection devices will need to be incorporated within the transformer or, alternatively, the transformer will need to feed an associated distribution board (often DP).

Circuits fed from single-phase transformers, which have CT or CTE secondaries, must incorporate protection in each pole. Circuits fed from single-phase transformers which have neutral earthed outputs should only incorporate single-pole protection, unless the protective device opens live and neutral poles simultaneously i.e. a double pole MCB. Earth free outputs should incorporate double-pole protection.

Circuits fed from three-phase transformers with neutral earthed outputs require protection in each pole. Double-pole protection is required for single-phase Reduced Low Voltage circuits derived from a three-phase (or single-phase) transformer.

RCD protection should only be fitted to the secondary side of double wound transformers and the secondary winding must be earthed.

MAGNETISING CURRENT

The inrush or magnetising current of Blakley transformers does not usually exceed 10-15 times the full load current in the half cycle following initial energisation. It is therefore recommended that supply fuses be motor rated and MCB's be Type "D" to BS EN 60898. Transformers with low magnetising current can be designed when close protection of supply cables is required or if a number of transformers installed on the same circuit are to be energised simultaneously.

TRANSFORMER REGULATION

The difference between the off-load and on-load voltage (Regulation) of Blakley transformers is generally within 5%, even on transformers rated less than 1000VA, which is a critical consideration when supplying voltage sensitive loads, such as 12 volt tungsten-halogen lighting.

TAPPINGS

The designed output voltage is only obtained when the input voltage is correct. Transformers with multiple tapped primary and secondary windings can be produced to enable variations in supply voltage to be accommodated. Tapping adjustment is off-load and tappings are normally incorporated into the higher voltage winding.

SOCKET-OUTLETS

A wide variety of sockets can be fitted to enclosed pattern transformers. The most popular range of sockets incorporated are those conforming to BS EN 60309 Parts 1 and 2 (formerly BS 4343). These are available in current ratings of 16, 32, 63 and 125 amps and voltages of 25, 50, 110, 240, 415, 500 and 750 volts. Plugs to BS EN 60309 are not fused, circuit protection must therefore be incorporated within the transformer or an associated distribution board. As an alternative to BS EN 60309, accessories conforming to BS 196 can be fitted but the range is far less extensive. Sockets conforming to other standards can be fitted as required.

THE POWER PROFESSIONALS

HIGHER POWER TRANS POWER SAFE POWER TEM POWER PRO POWER GREEN POWER

THE COMPANY RESERVES THE RIGHT TO CHANGE PRODUCTS WITHOUT PRIOR NOTICE.



Cert. No. 902091

TRPS&I - 01/08

Guidance on the Earthing of Secondary Windings

To enable us to supply transformers correctly configured for each installation it is necessary to specify the earthing arrangement of the secondary winding.

Secondary Voltage	Earthing Arrangement	BS 7671 Definition	Comments
Up to 50 Volts, single or three phase	Earth Free	Separated Extra Low Voltage (SELV)	Sockets to be 2P or 3P Over current protection to be DP or TP
Up to 50 Volts, single phase	Neutral Earthed	Protective Extra Low Voltage (PELV)	Sockets to be SP+N+E Over current protection to be SP
Up to 50 Volts, single phase	Centre-tapped to Earth	Protective Extra Low Voltage (PELV)	Sockets to be 2P+E Over current protection to be DP
110 Volts, single phase	Centre-tapped to Earth	Reduced Low Voltage (RLV)	Sockets to be 2P+E Over current protection to be DP
110 Volts, three phase	Neutral Earthed	Reduced Low Voltage (RLV)	Sockets to be 2P+E or 3P+E Over current protection to be DP or TP
120 Volts, single phase	Neutral Earthed	Low Voltage (LV)	Sockets to be SP+N+E. Over current protection to be SP. (USA domestic voltage)
208 Volts, three phase	Neutral Earthed	Low Voltage (LV)	208 volts L to L, 120 volts L to N. DY11. (USA industrial voltage)
230 Volts, single phase	Neutral Earthed	Low Voltage (LV)	Sockets to be SP+N+E Over current protection to be SP
230 Volts, single phase	Earth Free	Protection by Electrical Separation	Maximum of one socket (feeding one appliance). Over current protection to be DP
400 Volts, three phase	Neutral Earthed	Low Voltage (LV)	400V L to L, 230V L to N. DY11.
400 Volts, three phase	Earth Free	Protection by Electrical Separation	Maximum of one socket (feeding one appliance). Over current protection to be TP

Single Phase

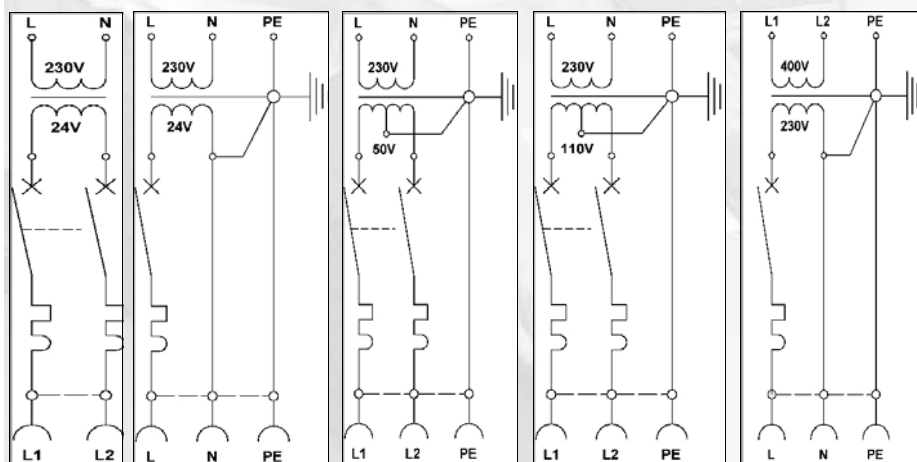

(i) SELV Earth Free
(ii) PELV Neutral Earthed
(iii) PELV Centre Tapped to Earth
(iv) RLV Reduced Low Voltage
(v) LV Neutral Earthed

Three Phase

(vi) RLV Reduced Low Voltage, 110V Three Phase

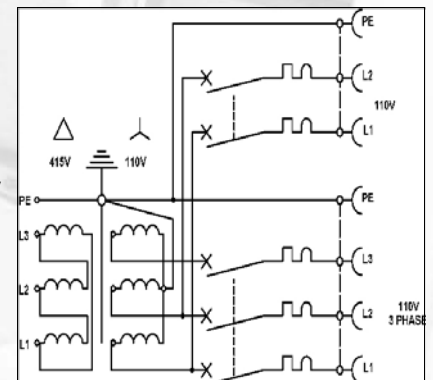

(vii) LV Three Phase, Delta/Star

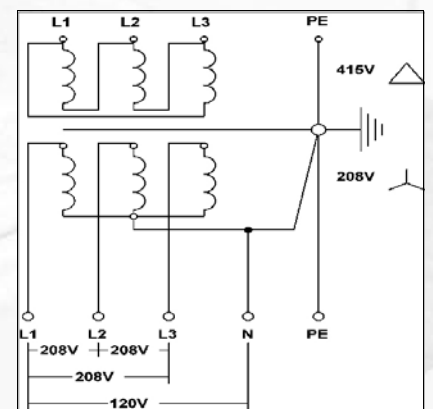

Typical Connection Diagrams

- SOUTH** 1 Thomas Road, Optima Park, Crayford, Kent DA1 4GA Tel: 0845 074 0084 Fax: 0845 074 0085
 - NORTH** Unit 55, Monckton Road Ind Estate, Wakefield WF2 7AL Tel: 0845 074 0086 Fax: 0845 074 0087
- www.blakley.co.uk • sales@blakley.co.uk